

MATH 2310: CALCULUS III

Instructor: Walker H. Stern

Email: ws7jx@virginia.edu

Office: Kerchof 311

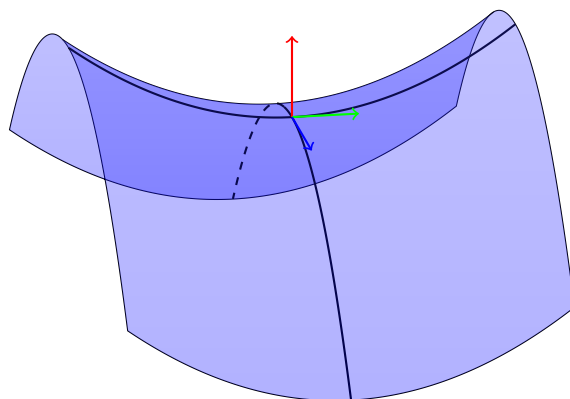

Class Meetings: TuTh 9:30–10:45am (Zoom link on Collab)

Discussion Section: We 1:00–1:50pm. TA: Filippo Mazzoli (ecu4xw@virginia.edu)

Office hours: Walker: Wed 3:00–5:00pm or by appointment.
Filippo: Mon 5:00–6:30pm. (Zoom links on Collab)

Required text: Multivariable Calculus, 8th ed., by James Stewart

Course Overview: This course provides an introduction to multivariable calculus in three dimensions. Over the course of the semester we will cover vectors and geometry in three dimensions, directional derivatives of multivariable functions, differentiation rules, optimization of multivariable functions, vector fields, integration over curves, surfaces and solids, and generalizations of the fundamental theorem of calculus to multivariable functions.

While some students will be familiar with some of the initial material covered in this course, it is *strongly* advised that students keep up with the course material. The course moves quickly, and the later topics will be quite challenging.

Online Learning: Owing to the COVID-19 pandemic, this course will be entirely online. Lectures and discussion sections will take place via Zoom, and assignments will be made available and submitted via Collab and Webassign. Students will additionally be expected to watch video lectures on Collab in preparation for course meetings.

In *all* online meetings, students *must* use their real name. Participants in Zoom sessions using nicknames, aliases, or joke names will be summarily banned.

Etiquette for online meetings

- Class meetings will *not* be recorded.
- Use a headset or earbuds to be sure you can hear and be heard easily when speaking, and to prevent echo.
- Please keep your microphone muted when you are not speaking so as to reduce background noise.
- Please be mindful to avoid interrupting other students.
- If I am writing, I may not be able to see the ‘raise hand button’ If this happens, feel free to simply unmute and ask your question.
- Students are strongly encouraged to turn their video on during class time. If your video is on, make sure you’re dressed appropriately for class.
- We will have to adjust to quirks of the technology as time goes on. Feel free to make suggestions to me after class on improving the ‘classroom’ experience. Any further suggestions will be posted on the course Collab page.

Prerequisites

- MATH 1320 or equivalent.

Outline

The following is an outline of the schedule we will try to follow. Owing to the unusual nature of online instruction this semester, this outline is subject to substantial change, and should be taken only as a loose guide to the course structure.

Weeks 1–2: Geometry and algebra of \mathbb{R}^3 . Dot product, cross product.

Weeks 3–4: Space curves, derivatives, integrals, curvature.

Weeks 5–6: Multivariable functions, partial derivatives, and extrema.

Weeks 7–8: Integration of scalar functions of multiple variables, Fubini Theorems, change of variables.

Weeks 9–10: Vector fields, integrals, the Gradient Theorem, conservative vector fields.

Week 11–13: Green’s Theorem, Stokes’ Theorem, and the Divergence Theorem.

Week 14: Review.

Evaluation & Grading

Percentage grades in the course will be assigned according to the following weighting:

Homework	40%
Reflections	5%
Classwork	20 %
Midterm # 1	10 %
Midterm # 2	10 %
Final	15%

Letter grades will follow the rule that 90–100% is an A, 80–89% a B, and so on. *No extra credit* will be provided.

Homework: Weekly homework assignments are a substantial part of the course grade. Homework will typically have two components: computational exercises on Webassign, and written exercises to be scanned and submitted via Collab. Access to Webassign requires a login, which can be obtained either as part of the purchase of the required text or independently. The book is available as a physical book or an ebook. To access the course’s Webassign page, you will need the course code **virginia 1312 5345**. For students as yet uncertain whether they will continue taking the class, please note that Webassign offers a 14 day free trial period, which will allow you to participate before deciding whether to purchase the required login.

Midterms: There will be two midterms, tentatively scheduled for Thursday, October 1st and Thursday, October 29th. The midterms will be time-limited, take-home examinations, and both will be cumulative. The details of the midterms may change in the coming weeks. Students will be informed of any changes well in advance of the examinations.

Final examination: The final will be a comprehensive oral examination conducted via Zoom. Students will be expected to answer questions about the course material, and to perform some basic computations.

Video Lectures: Video lectures will be posted in the Media Gallery of the course Collab page. Students will be expected to watch the video lectures prior to attending class. The description of each video lecture will include questions the student should think about *before* watching the video.

Reflections: Once a week, students will be asked to write a one-to-two paragraph reflection on material from the video lectures that week. These will focus on intuition, understanding, and underlying concepts. Reflections will be submitted via the course Collab page, and will be graded pass/fail.

Classwork: Some class time will be set aside for discussion and group work on problems. These problems will be handed in at the end of class, and will count toward the final grade.

Attendance: While attendance is not strictly mandatory, students will lose credit for any classwork in course sessions they do not attend. Students with a good excuse for their absence can contact the lecturer by email to discuss the possibility of making up the classwork.

Accommodations: Students with a disability which requires accommodation should contact the **Student Disabilities Access Center** (SDAC). Students without accommodation letters

from the SDAC will not be provided accommodations in class or on exams.

Forum: There is a class forum (Piazza) set up on Collab, which the instructor and TA will check regularly. Students are encouraged to ask and answer questions about the course material and assignments on Piazza. Students can access Piazza via the course collab site, or via the class sign-up link: <https://piazza.com/virginia/fall2020/stern231ofall2020>.

Academic Honesty: All exams in this course fall under the purview of the UVA honor code. Remember to pledge each examination.

Instructor Communication: Throughout the semester, the instructor will send you emails through the course Collab page. You are responsible for the contents of these communications. These communications may include the scheduling of examinations, cancelled or rescheduled classes, or information about homework. You may communicate with the instructor via email, Collab, or Zoom (the latter by appointment or during office hours).

Resources: Students are *strongly* encouraged to take advantage of the office hours held by the instructor and the TA. Additionally, students should consider taking advantage of the *free Math Collaborative Learning Center* (MCLC), which offers math help for a number of courses, Math 2310 included.